

M73 Hatch 120l, kinshofer

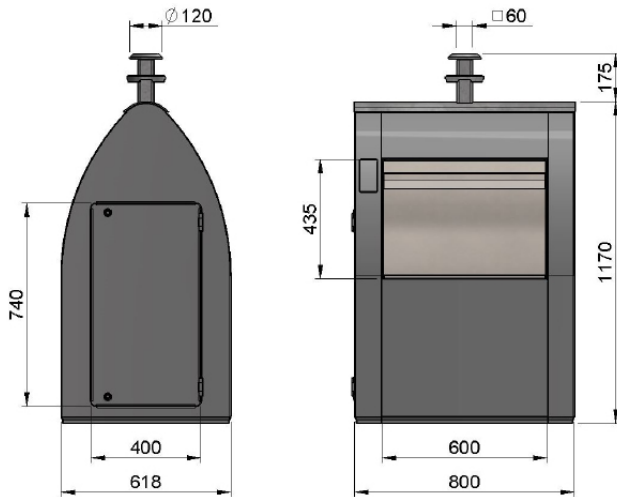

General specifications

Model	: Metro® M73
Product type	: Underground container
Hoisting system	: Kinshofer
Inlet	: Hatch 120l, stainless steel 304

Material

Pillar	: 3mm S235JR, fully welded
Lower body	: 3mm S235JR, fully welded
Bottom hatches	: 3mm S235JR, fully welded
Pedestrian platform	: 4/6 tear plate S235JR, 1450x1450mm

Preservation

Galvanisation	: Welded parts are hot dip galvanized acc. to DIN-EN-ISO 1461
Coating of pillar	: Powder coating acc. to DIN-EN 15773

Quality and environment

System compliant with NEN-EN 13071 -1, -2 and -3
 Product with TÜV type approval and CE marking
 All our underground containers can be returned for recycling

Options

Container Sizes	Height excl. pillar	Height incl. pillar	Total weight
3m ³	1.604mm	2.775mm	520kg
4m ³	2.164mm	3.335mm	600kg
5m ³	2.724mm	3.895mm	680kg

Access control

Mechanical	: ASSA-lock
Mechanical	: Euro-cylinder
Electronic	: Chiplock® 5.0

Can be combined with

Metro® saloon door safety system (sdss)
 Metro® concrete box